

MB-Q SERIES SPECIFICATIONS		MB-10Q	MB-14Q	MB-16Q
MACHINE CAPACITY	X Travel	32"	40"	60"
	Y Travel	17"	20"	25"
	Z Travel	19"	20"	24"
	Ballscrew Size	1.26"	1.26"	1.57"
	Table Load (Evenly Distributed)	2,000 lbs.	2,450 lbs.	2,950 lbs.
	Table Size	14" x 50"	16" x 54"	18" x 70"
	T-Slots (No./Width)	3 / 0.630"	3 / 0.630"	5 / 0.630"
Table Top to Floor	31"	33"	36"	
SPINDLE	Motor HP (Peak)	10 HP	10 HP	10 HP
	Spindle Speed (RPM)	Low 10-500 High 100-4,500		
	Spindle Torque (max)	40 ft/lbs High Gear - 238 ft/lbs Low Gear		
	Speed Ranges	2 Speed Gear Box		
	Tool Type/Taper	CAT 40 (NST 40 or BT 40 Optional)		
	Quill Diameter	4.125"	4.125"	4.330"
	Quill Travel	6"	6"	6"
	Spindle Nose to Table (Max to Min)	23" - 4"	26" - 6"	30" - 6"
	Spindle Center to Column	17.5"	20"	25"
Head Swivel	+/- 90°	+/- 90°	+/- 90°	
PERFORMANCE	Positioning Accuracy	+/- 0.0002"		
	Positioning Repeatability	0.0001"		
	Rapid Traverse	400 IPM		
	Cutting Feed Rate	0.001 - 300 IPM		
	Axis Thrust (Peak)	4,400 lbs.		
GENERAL INFO	Air Pressure Requirements	85 PSI; 3 CFM		
	Coolant Capacity	12 Gallons		
	Coolant Flow	3 Gal/Min		
	Power Requirements	40 AMP; 208-240 VAC 3 PHASE (380-500 optional)		
	Shipping Dimensions* (WxDxH)	50" x 76" x 76"	54" x 80" x 78"	72" x 92" x 89"
	Operating Dimensions (WxDxH)	103" x 80" x 94"	113" x 80" x 106"	174" x 92" x 113"
Machine Weight	5,000 lbs.	6,000 lbs.	8,800 lbs.	

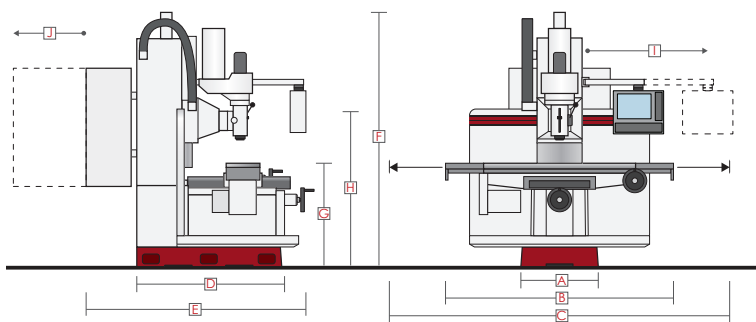

	MB-10Q	MB-14Q	MB-16Q
Floor Width (A)	26"	26"	33"
Overall Width (B)	82"	82"	111"
X-Axis Movement (C)	103"	113"	174"
Floor Depth (D)	56.5"	56.5"	66"
Overall Depth (E)	80"	80"	92"
Maximum Height (F)	94"	106"	113"
Floor to Table Height (G)	33"	33"	36"
Floor to Console Height (H)	62"	62"	62"
Console Swing Radius (I)	60"	60"	42"
Electrical Cabinet Swing (J)	37"	37"	36"
Approx. Machine Weight	5,000 lbs.	6,000 lbs.	8,800 lbs.